

KRIS XL-70

INSTALLATION AND OPERATING INSTRUCTIONS



CEDARBURG, WI 53012

414/377-5700

Telex 2-6886

The materials that went into the XL-70 are of the highest possible quality. Only thoroughly trained electronic personnel have been employed in the manufacture of this, and all KRIS products. The XL-70 has been inspected seven (7) different times to assure you of the high quality that people have come to expect from KRIS.

KRIS, INC., located in Cedarburg, Wisconsin, has been involved in the manufacture of Citizens Band equipment for many years. During this period of time we have learned what you want and expect in a good Citizens Band set. We used all this knowledge and experience in the engineering of the XL-70.

KRIS offers you all of the additional equipment (which has been specially matched) that you need to operate your XL-70. Equipment such as: antennas, coax, connectors, meters, microphones, speakers, and preamplifiers.

Additionally, KRIS offers matching base stations and accessories so you can operate a complete communications system. KRIS also offers many other Mobile, AM, and Single Side Band sets. The next time you need any Citizens Band equipment — be sure to look for KRIS.

THIS UNIT TYPE ACCEPTED UNDER F.C.C. RULES AND REGULATIONS PART 95

— SPECIFICATIONS —

GENERAL

Modulation mode	: Conventional AM and suppressed carrier SSB
Self-contained speaker	: 2" by 3½", 4 ohm voice coil
Microphone	: Dynamic microphone with push-to talk switch
Controls, indicators, and connectors	: Volume control with on-off switch : Variable squelch control : R.F. gain control : Channel selector : Variable tune control : AM/SSB selector switch : Sideband selector switch : Noise blanker switch : PA switch : Speaker selector switch : Transmit indicator lamp : AM mode lamp : SSB mode lamp : Illuminated S/RF meter : Microphone connector : External speaker jack : PA speaker jack : External "S" meter jack : Antenna connector : Transmit relay contact
Power supply	: 13.8 volts DC, + or - ground
Dimensions	: 9.375" (D) by 8.250" (W) by 2.688" (H) (23.8 cm by 21.0 cm by 6.8 cm)
Weight	: Unit — 5 lbs. (2.27 kg) : Shipping — 5½ lbs. (2.49 kg)

RECEIVER

Frequency range (MHz)	: 26.965 - 27.255
Sensitivity	: 0.7 μ V for 10 dB S/N (AM) : 0.2 μ V for 10 dB S/N (SSB)
Selectivity	: \pm 3.0 KHz at 6 dB down (AM) : \pm 1.2 KHz at 6 dB down (SSB)

Adjacent channel rejection	: Greater than 65 dB
A.G.C. range	: Greater than 80 dB
Squelch sensitivity (threshold)	: Less than 0.7 uV
Spurious response	: More than 60 dB
Audio power output	: 2 watts at 10% distortion

TRANSMITTER

Frequency range (MHz)	: 26.965 - 27.255
RF output power	: 4 watts max. (AM) : 12 watts PEP max. (SSB)
Modulation capability	: 95% (AM)
Spurious suppression	: More than 50 dB
Frequency tolerance	: $\pm 0.005\%$, -20 degrees C to +50 degrees C

FEDERAL COMMUNICATIONS COMMISSION REQUIREMENTS

Your new KRIS XL-70 is a combination receiver — transmitter designed and built for licensed Class D operation on any of the 23 frequencies designed as citizens band channels by the Federal Communications Commission. You are required to read and understand Part 95 of the F.C.C. rules and regulations prior to operation of this unit. Part 95 regulations are contained in Volume VI of F.C.C. rules and regulations. Volume VI is available from the Superintendent of Documents, Government Printing Office, Washington D.C. 20402. The cost for Volume VI is \$5.35. You are also required to complete F.C.C. Form 505 and submit it to the F.C.C. in order to receive your license to operate this unit. F.C.C. regulations will be violated if you transmit with this unit prior to receipt of your license.

NOTE:

The technical information, diagrams, and charts provided in this manual are supplied for the use of a qualified holder of a first or second class radiotelephone license in servicing this transceiver. It is the user's responsibility to see that this unit is operating at all times in accordance with F.C.C. Citizens Radio Service regulations.

If you install or service your own transceiver, do not attempt to make any transmitter tuning adjustment. Transmitter adjustments are prohibited by the F.C.C., unless you hold a first or second class radiotelephone license, or are in the presence of a person holding such a license. A Citizens Band or Amateur license is not sufficient.

KRIS, INC., HEREBY CERTIFIES THAT THIS EQUIPMENT HAS BEEN DESIGNED, MANUFACTURED, AND FURNISHED IN ACCORDANCE WITH VOLUME VI, PART 95 OF THE CURRENT FCC RULES AND REGULATIONS FOR CLASS D CITIZENS BAND OPERATION.

— GENERAL DESCRIPTION —

The KRIS XL-70 is a transceiver employing a frequency synthesizer circuit providing 23 crystal controlled transmit and receive channels in the 27 MHz Citizens Band. The unit is all solid state, utilizing an FET front end in the receiver. It can be operated in the conventional AM mode, or in the single sideband suppressed carrier (SSB) mode, using either the upper (USB) or lower sideband (LSB). In the sideband mode, up to 46 channels are available. The transceiver has been carefully designed for ease of operation. Selection of AM, upper sideband, or lower sideband is achieved by a mode switch.

When using conventional AM transmission modes, the carrier wave is radiated whenever the transmitter is on. When the operator speaks, and modulation takes place, double sidebands (both upper and lower) are generated. All of the speech information is contained in each of the sidebands. The carrier, which uses most of the power, is used only to transfer the audio to the receiver.

The use of single sideband (SSB) can give an effective gain of 9dB over conventional AM — equivalent to increasing the transmitter power 8 times. This is possible since the carrier is not transmitted, allowing all of the power available to be used in transmitting one sideband. When transmitting on SSB, RF power is generated only while actually talking.

AM double sideband requires a 6 KHz band width, while single sideband requires only half — 3 KHz. This narrow bandwidth allows less noise to be received, and thus enables weaker signals to be received more clearly.

This unit includes every necessary feature for optimum communications: variable squelch, noise blanker, noise limiter (AM only), RF gain, fine tuning, public address operation, and an S/RF meter. It is designed for mobile operation from a 12 volt DC supply, but can also be used as a base station by addition of the optional KRIS power supply.

— INSTALLATION —

TRANSCEIVER LOCATION:

Before installing the XL-70 in the car, truck, boat, etc., make certain to use a location which permits the driver to operate the controls of the unit without interfering with his driving functions. The transceiver can be mounted to the underside of the instrument panel, on the floor, or above the driver's head if in a truck cab. Using the bracket as a pattern, locate the positions of the screws and drill holes.

After mounting the bracket, secure the transceiver to the bracket by means of the knurled screws.

POWER SUPPLY:

Almost all cars and most trucks currently operating in the U.S. are negative ground. There are some large trucks and construction equipment which do operate on positive ground. Your KRIS XL-70 will operate on either.

NEGATIVE GROUND HOOKUP:

Attach the red (fused) wire to the fuse block terminal or any convenient plus (+) lead. Devices operated by the ignition key such as the radio, light, etc., are best since when you turn the ignition off, the unit will be turned off. Attach the black lead to the car body via any convenient method.

NOTE: Many newer cars use plastic dash pieces. Make sure the screw or contact you choose is attached to the metal framework of the car.

POSITIVE GROUND HOOKUP:

In the event that you do have a positive ground vehicle, the following hookup must be made. Attach the red (fused) lead to the car body via any convenient screw, bolt, etc. Attach the black lead to the terminal block or any convenient wire which goes to the minus (-) pole of the battery.

FAILURE TO MAKE THE PROPER CONNECTION COULD RESULT IN UNIT DAMAGE.

If the inline fuse blows, recheck your installation to make sure it is correct. NEVER REPLACE FUSE WITH ONE OF HIGHER RATING (3.0 amps) AS THIS COULD CAUSE DAMAGE TO THE TRANSCEIVER. REPLACE—MENT OF FUSE WITH ONE OF HIGHER RATING, OR OPERATING THE UNIT WITHOUT A FUSE VOIDS THE WARRANTY OF THE TRANSCEIVER.

ANTENNA REQUIREMENT:

This transceiver will operate with any properly constructed antenna designed to operate in the 26.96 to 27.26 MHz Citizens Band. A standard SO 239 type connector is provided on the back panel for use with popular PL 259 antenna plug.

The XL-70 is a highly efficient communication system, however as in any complicated system, the results are only as good as the weakest component in the chain. In most cases, this is the antenna system. Only a properly tuned antenna will allow maximum efficiency of your unit.

The specific instructions included with your antenna are the best source of information regarding tuning and matching. Most "word of mouth" gimmicks for antenna tuning are less than effective and could ultimately damage your unit through extreme mismatch conditions. The recommended general method for tuning antennas involves the use of a Standing Wave Ratio (SWR) bridge, or an inline wattmeter. Read carefully the instructions relating to the operation of these devices before attempting their use. An antenna with an SWR of 1.5 to 1 or less will provide the best performance. The unit should not be operated into an antenna system with an SWR of higher than 2.0 to 1, as possible damage to the output transistor could result. This tuning should be performed with the unit in the AM mode.

Tuning the antenna system of your installation is a very important part of your communications system. Both the receiver and transmitter of your station will be at peak performance if a properly matched antenna system is used.

— NOISE INTERFERENCE —

In mobile installation, electrical noise usually limits the use of the receiver at low signal levels. The noise issues from two automotive systems; the generator or alternator, and the ignition system.

The XL-70 is equipped with an effective series gate type automatic noise limiter system (ANL) in the AM mode, and a switchable noise blanker, which is used for both AM and SSB. This system operates on the noise caused by the ignition system. The XL-70 also contains a bypass circuit system to eliminate the noise caused by the automobile electrical system. In cases where interference is severe, additional noise filtering networks are available from KRIS for installation on your automobile.

Care should be taken when installing your XL-70 to avoid problems which could cause noisy operation. Each connection made to your transceiver should be clean and corrosion free. Connections exposed to the elements should be protected from moisture with waterproof tape or a sealing compound. The transceiver should be connected to the power source using short lengths of heavy wire rather than thin wire. Special attention should be given to the installation of the coax connectors to insure proper contact. Follow the recommendations included with your antenna regarding grounding the base of the antenna.

Time spent in making a mechanically and electrically sound installation will insure quiet, trouble-free operation.

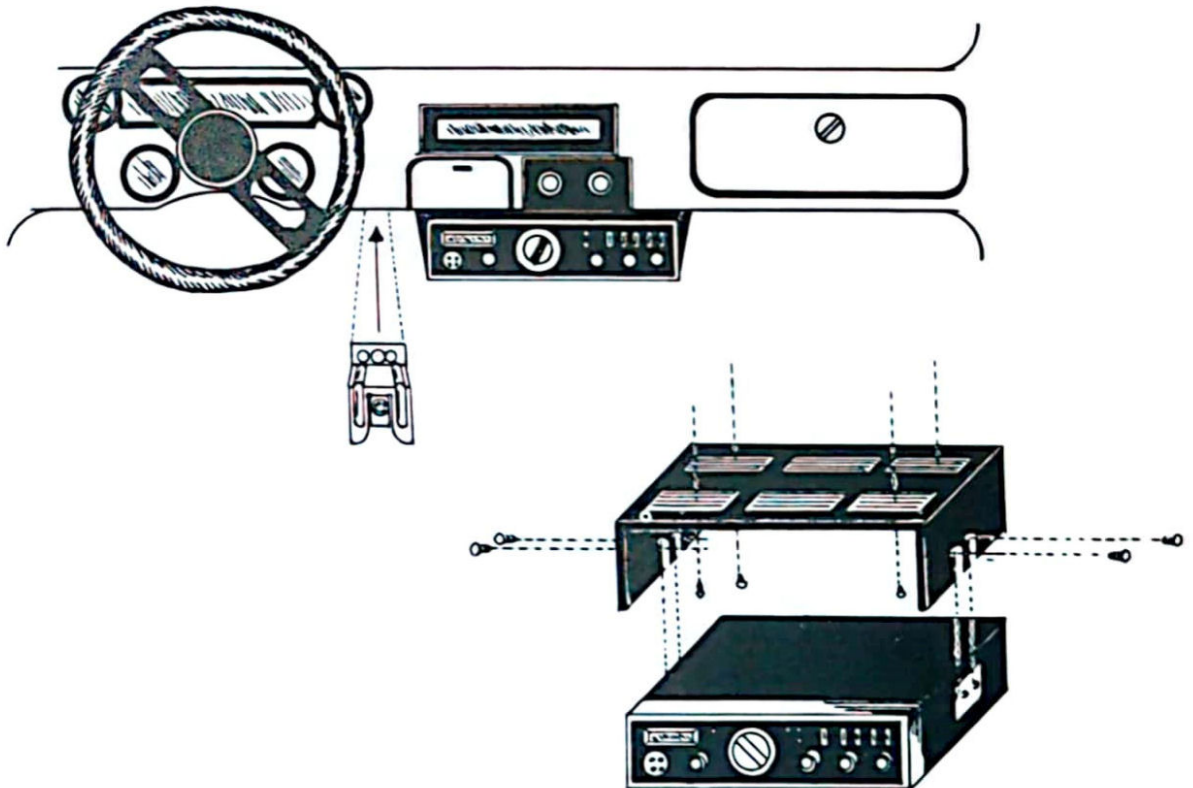

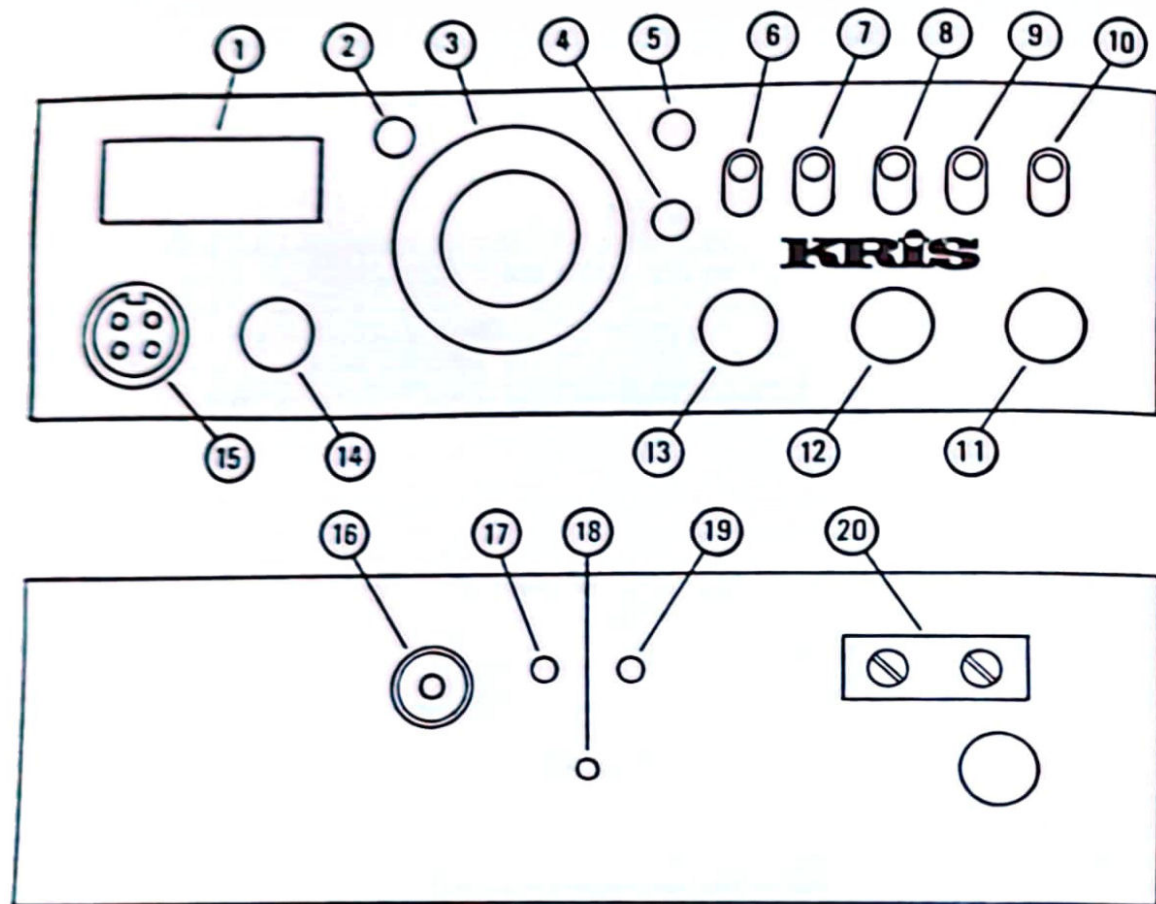

— OPERATING CONTROLS AND FEATURES —

1) S/RF METER:

This meter is automatically switched to indicate incoming signal strength in the receive mode, and relative RF power output in the transmit mode.

2) TRANSMIT INDICATOR:

The red light emitting diode will glow when the push-to-talk button is pressed and the unit is in the transmit mode.

3) CHANNEL SELECTOR SWITCH:

Tuning of the receiver and transmitter is done simultaneously by rotating the 23 channel selector switch. Set the switch to the desired channel 1 to 23 as indicated directly on the switch knob.

4) SSB MODE INDICATOR:

This indicator shows that the SSB mode of operation has been selected.

Operating Controls and Features
(con't)

- 5) AM MODE INDICATOR:
The green indicator denotes selection of Amplitude Modulation.
- 6) AM/SSB SWITCH:
Selects between AM and SSB mode of operation.
- 7) SIDEBAND SELECTOR SWITCH:
Selects between upper and lower sideband (USB or LSB).
- 8) NOISE BLANKER SWITCH:
This switch activates a very effective type of noise blanking circuit. The noise blanker is usually left "on" in mobile operation due to higher noise levels encountered.
- 9) PUBLIC ADDRESS SWITCH:
When the "CB-PA" switch is in the PA position, your transceiver is converted to a public address system.
- 10) SPEAKER SELECTOR SWITCH:
Selects internal or external speaker.
- 11) RF GAIN CONTROL:
Rotating this control counter-clockwise reduces the receiver sensitivity when talking to close stations. Normally, the control should be fully clockwise.
- 12) SQUELCH CONTROL:
The squelch control is designed to reduce excessive noise when no signal is being received.
- 13) VOLUME CONTROL AND OFF-ON SWITCH:
The volume control varies the sound output of the loudspeaker. It also functions as an "off-on" switch. Clockwise rotation increases volume.
- 14) TUNE CONTROL:
Permits slight adjustment of receiver tuning used for clarity on SSB reception and fine tuning on AM reception.
- 15) MICROPHONE CONNECTOR:
Attach the four pin connector at the end of the microphone coil cord into the microphone connector. Be certain that it is secured firmly with the knurled ring.

Operating Controls and Features
(con't)

16) ANTENNA CONNECTOR:

Standard SO-239 jack to accommodate PL-259 plug.

17) EXTERNAL SPEAKER JACK:

3.5 mm jack for connection of optional accessory KRIS speaker.

18) EXTERNAL METER JACK:

2.5 mm jack for connection of optional accessory KRIS "S" Meter.

19) P.A. SPEAKER JACK:

3.5 mm jack for connection of optional accessory P.A. horn type speaker.

20) TRANSMIT RELAY CONTACT:

This normally open contact closes when the transmitter is keyed.

— GENERAL OPERATING INSTRUCTIONS —

CAUTION: Before operating this transceiver, you are required by law to read and thoroughly understand part 95 of the F.C.C. rules and regulations.

Check to see if the proper connections have been made on power cable, antenna system, and microphone, and that the correct cables have been used. Be sure that the transceiver is adequately grounded.

RECEIVE MODE:

Place the PA-CB switch in the CB position, and set the AM/SSB switch in the desired mode. Rotate the squelch control to the extreme counterclockwise position, set the RF gain control fully clockwise for maximum sensitivity, and select desired channel. Rotate the volume control knob until the on-off switch clicks, and the unit is in the "on" position. The meter light will glow softly. Advance the volume control about 50%. You will hear the characteristic rushing sound of the receiver. Adjust the volume control to a comfortable listening level. Adjust the tune control to fine tune AM signals and to clarify SSB signals.

SQUELCH ADJUSTMENT:

The squelch control is used to eliminate background noise when there are no signals present on the channel. To adjust the squelch control select a channel where there is no signal. Turn the volume up to a fairly high level. Rotate the squelch control clockwise until the background noise disappears. This point is called the "squelch threshold" and at this squelch position the receiver will be quiet when there is no signal on the channel, but an incoming signal will be able to overcome the squelch action and be heard. This control is variable, and as it is advanced, the squelch

action is increased. Consequently a stronger signal is required to break the threshold. To receive extremely weak signals or to disable the squelch circuit, merely turn the control fully counterclockwise. It is recommended that the squelch be disabled when in the SSB mode, or the receiver may squelch on low speech levels.

TRANSMIT MODE:

Before using the unit to transmit, make sure that the "PA-CB" switch is in the CB position. Select the channel on which you want to operate, making certain that there is not other traffic on that channel. Select AM or SSB mode. To transmit, simply press the microphone button. Holding the Mic 2-3 inches from mouth, speak into it at a normal voice level. The red transmit light will indicate that you are in the transmit mode.

When the unit is transmitting, the receiver is silent — consequently reception is impossible when you are in the transmit mode. In like fashion, your signal cannot be heard by another station when it is transmitting. Each station must take its turn.

CAUTION: DO NOT OPERATE TRANSMITTER WITHOUT AN ANTENNA OR 50 OHM DUMMY LOAD CONNECTED, AS THE OUTPUT TRANSISTOR MAY BE DAMAGED.

PUBLIC ADDRESS OPERATION:

Provision has been made for utilizing the XL-70 for public address operation. For PA, connect an external 4-8 ohm speaker into the phone jack, identified "PA- Sp." at the rear of the unit. Set the "PA-CB" switch to PA, and press the push-to-talk button on the microphone, and talk into it as you would when transmitting on a CB channel. Your voice will be heard on the external speaker. The transmitter and receiver are inoperative in the P.A. mode.

CAUTION: Do not ground either speaker lead to vehicle frame or chassis.

EXTERNAL SPEAKER OPERATION:

The optional KRIS accessory speaker can be used with the XL-70 to provide remote reception of CB signals. For this operation, connect the speaker into the phone jack identified "EXT. SP" at the rear of the unit. Attachment of a remote speaker will automatically silence the built-in speaker. To utilize the PA speaker for CB listening, switch speaker selector to "EXT."

CAUTION: Do not ground either speaker lead to vehicle frame or chassis.

TRANSMIT RELAY CONTACT:

The XL-70 is equipped with a relay which switches when the unit is transmitting. The terminal labeled NORMAL is grounded at all times to the black power lead. The terminal labeled OPEN is open when the unit is in receive, and becomes grounded when the unit is switched to transmit. Never connect a 12 volt source directly to either terminal. The contact may be used for turning other devices on and off, as the unit is switched between transmit and receive. The current limit of this contact is 2 amps. Higher currents will damage the relay.

EXTERNAL METER JACK:

A 2.5 mm phone jack in the rear of the XL-70 permits the use of an external S/RF meter. Simply plug the optional KRIS "S" Meter into the jack, making sure not to ground either meter wire to the case or vehicle chassis or frame. Attachment of the external meter disconnects the internal meter.

SERVICE:

In the event that your XL-70 requires service — either in or out of warranty — we suggest that you return it to the dealer from which it was purchased.

In the event that you return it directly to KRIS, Inc., pack the unit in its original carton. If the original carton is not available, make certain that you use a sturdy carton with sufficient shredded paper or other packing material to prevent shipping damage.

Include a letter with the unit indicating what is wrong with the transceiver. **DO NOT SHIP BY PARCEL POST.** Use Railway Express or United Parcel Service. **SHIP PREPAID.** Mark the carton "Fragile" and clearly address the carton as follows:

Service Department
KRIS, INC.
Cedarburg, WI 53012

CRYSTAL FREQUENCY CHART

		11.705MHz	11.755MHz	11.805MHz	11.855MHz	11.905MHz	11.955MHz
LSB	7.4585MHz	1	5	9	13	17	21
AM. USB	7.4615						
LSB	7.4685MHz	2	6	10	14	18	22
AM. USB	7.4715						
LSB	7.4785MHz	3	7	11	15	19	—
AM. USB	7.4815						
LSB	7.4985MHz	4	8	12	16	20	23
AM. USB	7.5015						

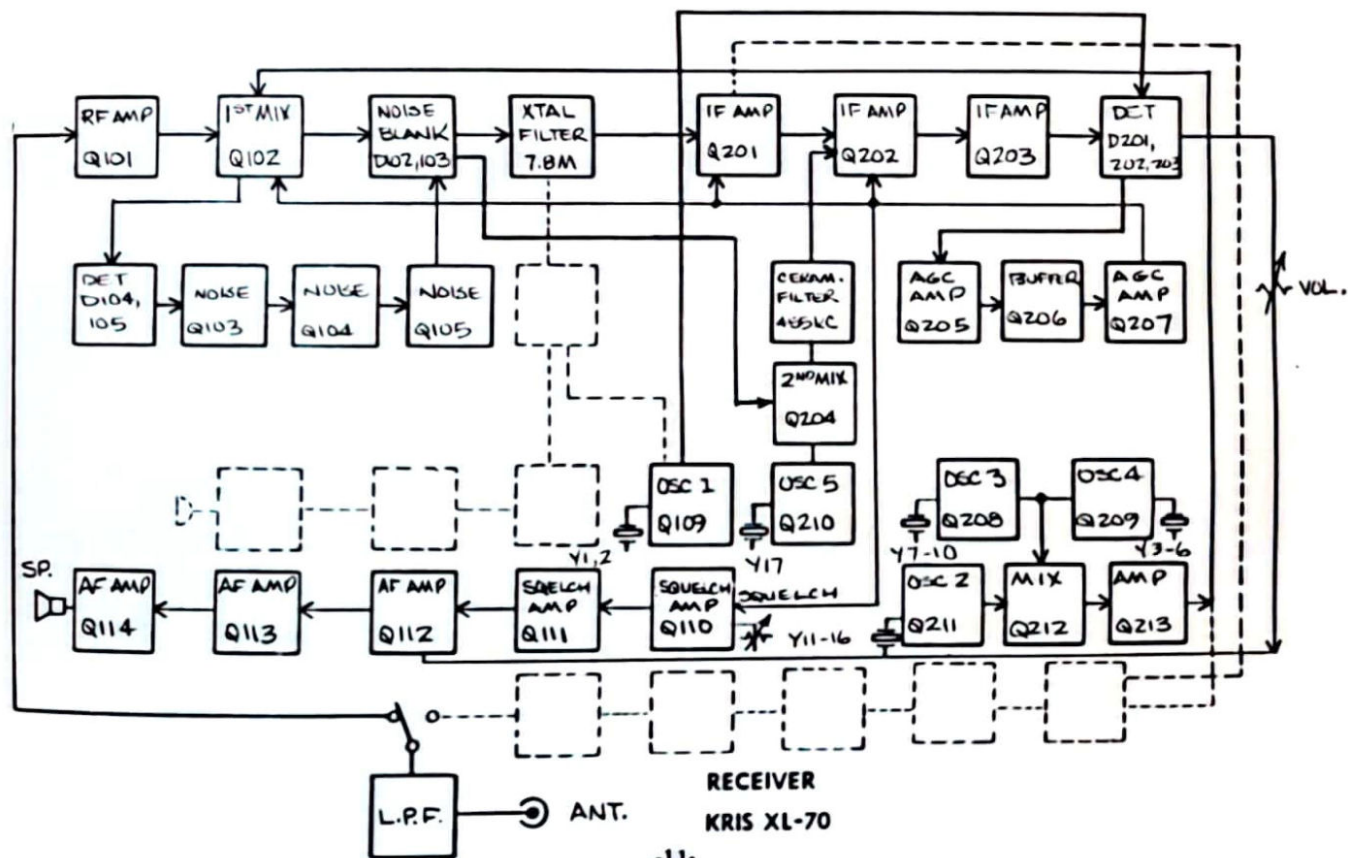
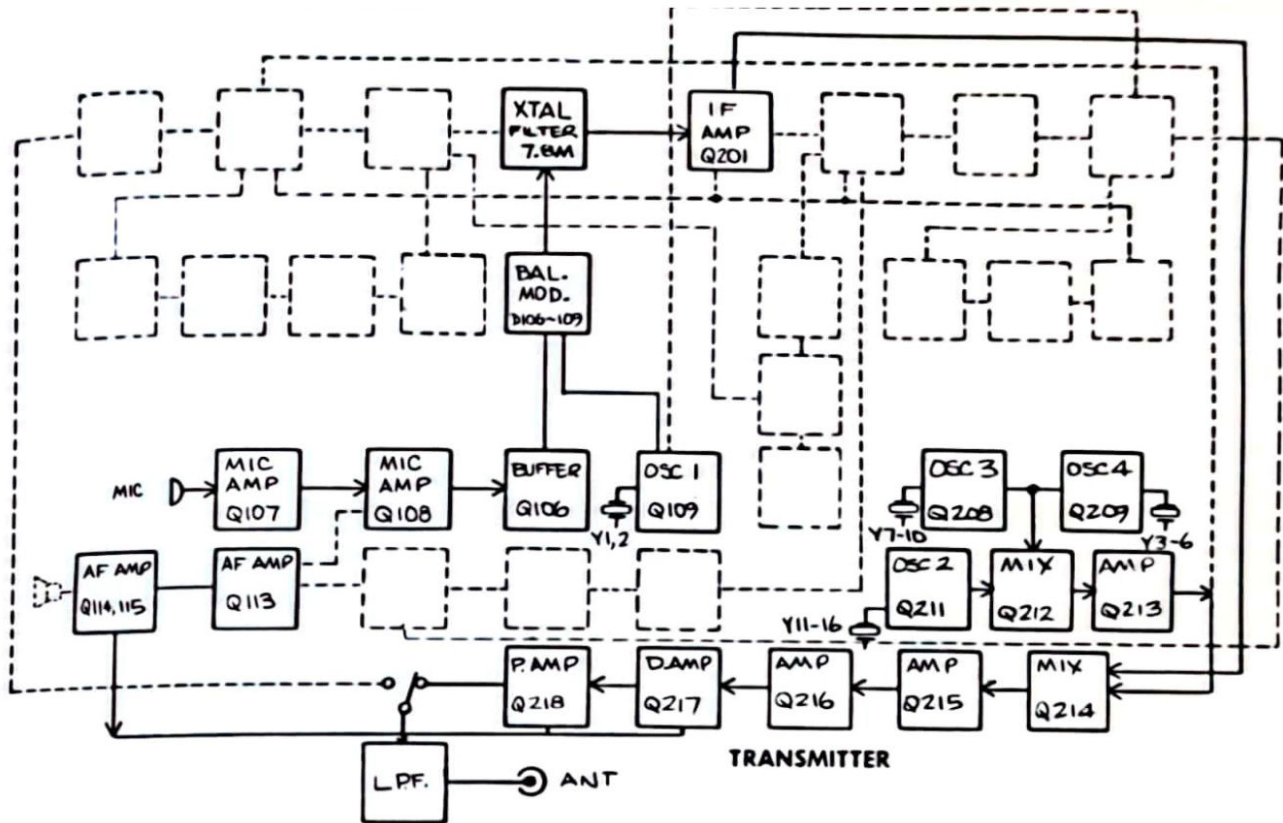

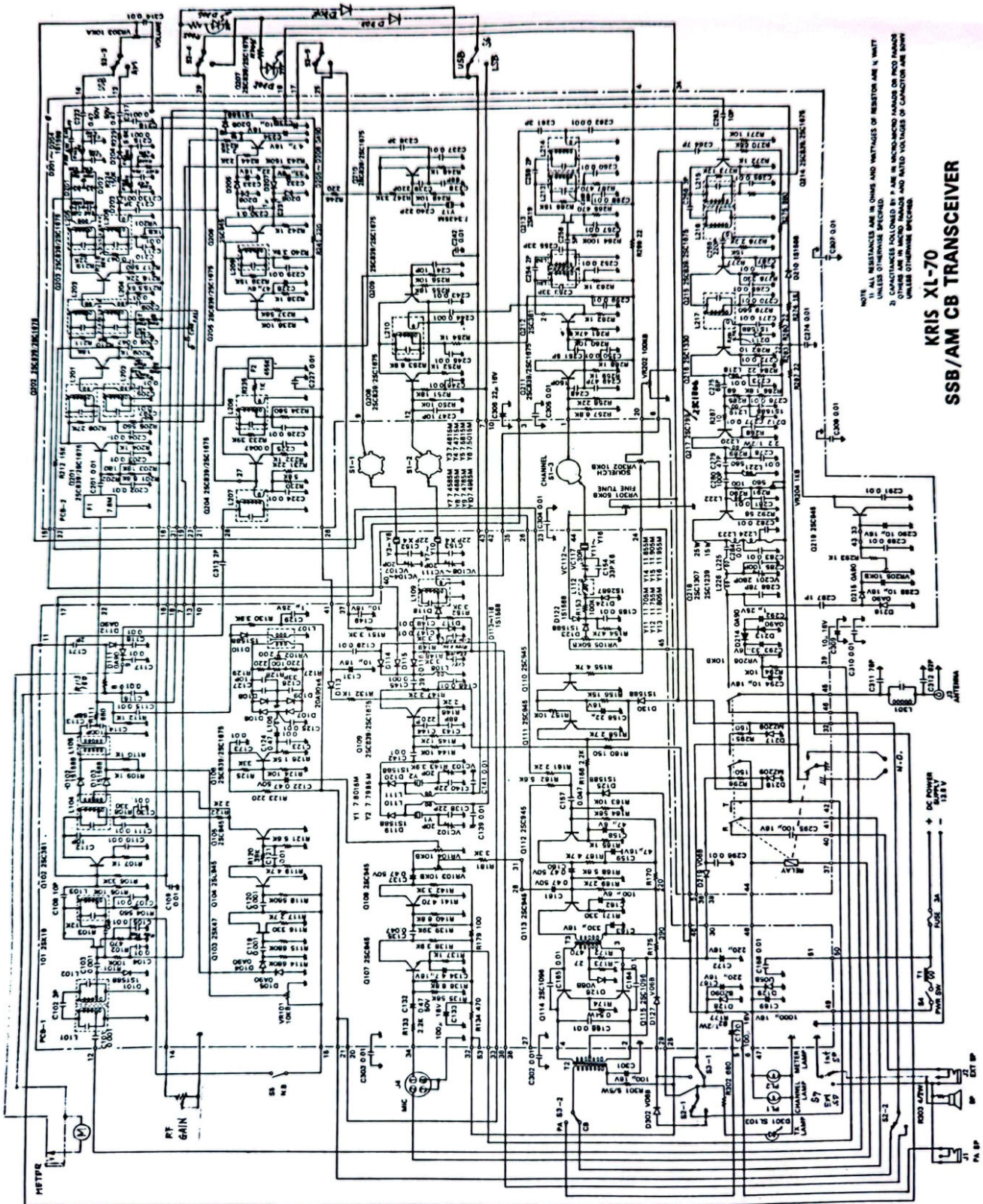

NOTE
 1. ALL RESISTANCES ARE IN OHMS AND CAPACITANCES ARE IN P.F. UNLESS OTHERWISE SPECIFIED.
 2. CAPACITANCES ARE IN MICROFARADS OR PICO FARADS UNLESS OTHERWISE SPECIFIED.
 3. OTHER ARE IN MEGAS AND KILLO VALUES OF CAPACITORS ARE IN P.P.F.

KRIS XL-70 SSB/AM CB TRANSCEIVER

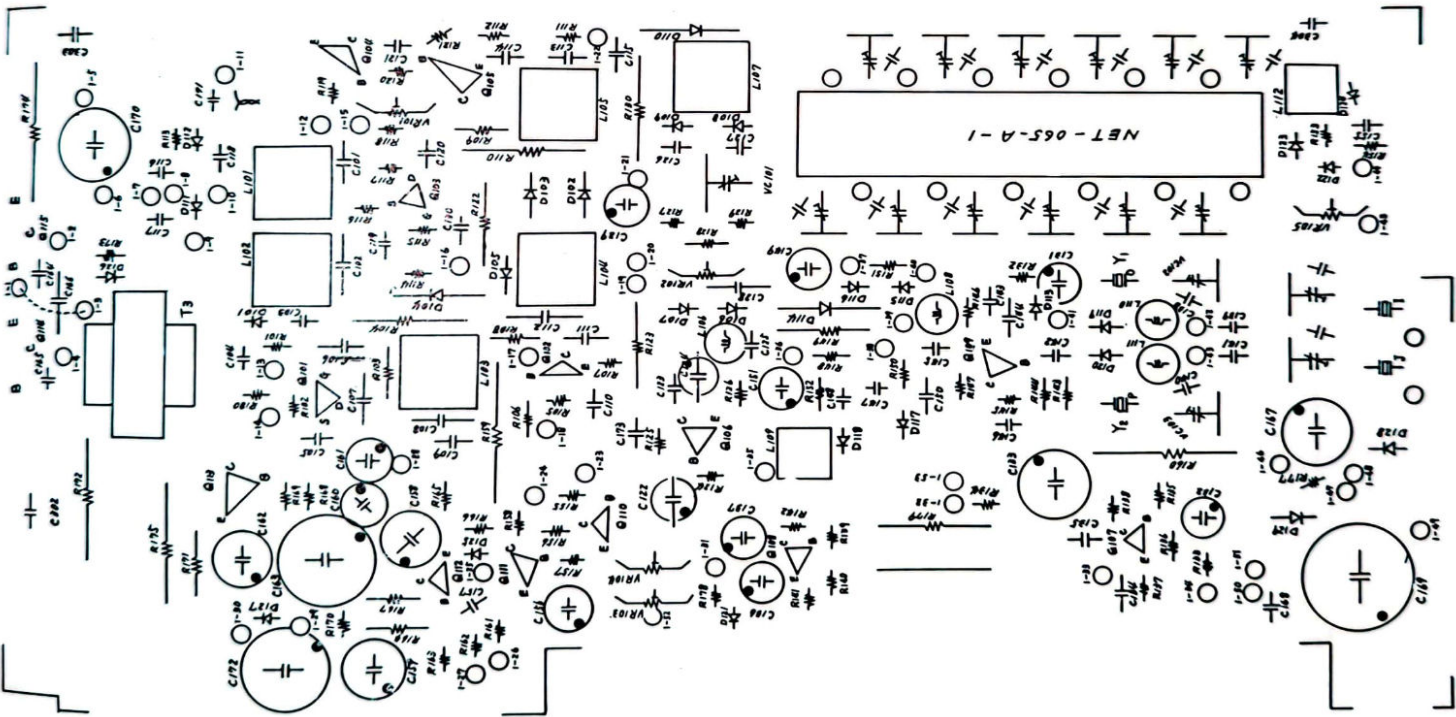
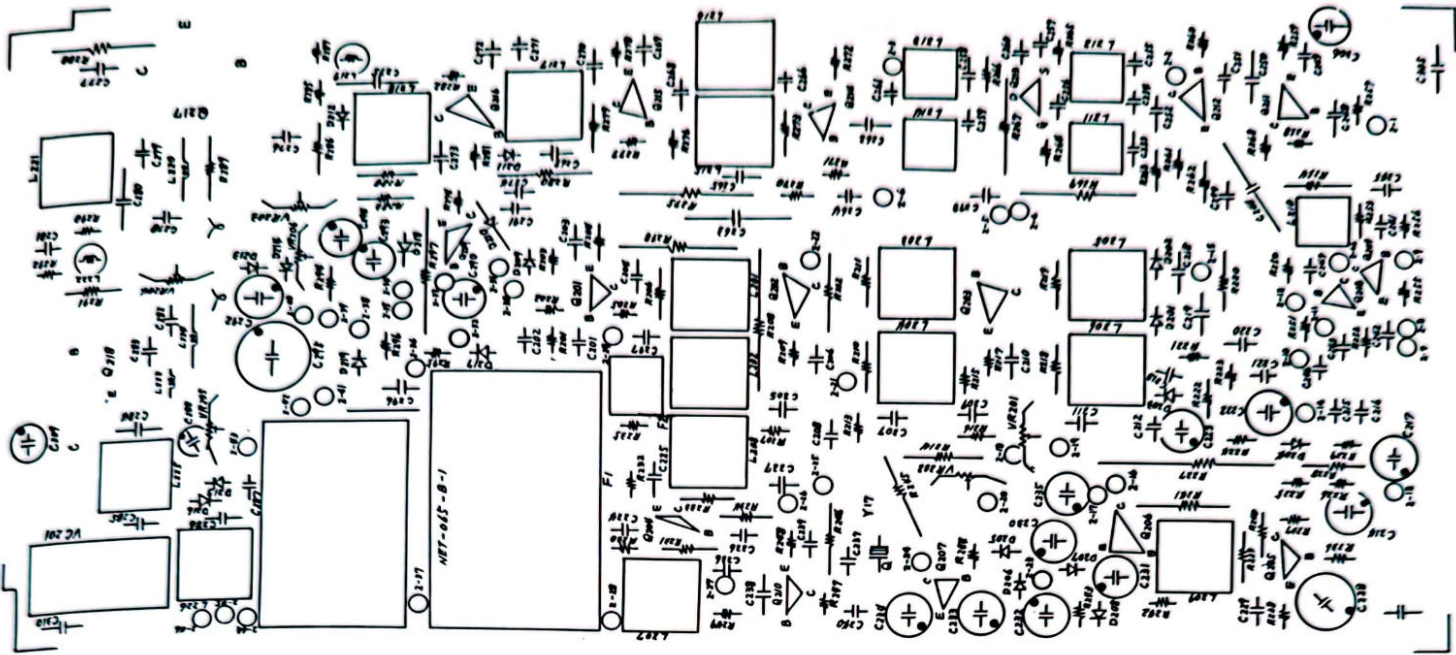

CAPACITORS:

<u>Part</u>	<u>Description</u>	<u>Part</u>	<u>Description</u>	<u>Part</u>	<u>Description</u>
C101	50V 0.001 uF Ceramic	C169	16V 1000uF Electrolytic	C263	50V 10pF Mica
C102	50V 3pF Mica	C170	16V 100uF Electrolytic	C264	50V 7pF Mica
C103	50V 0.001 uF Ceramic	C171	50V 2pF Mica	C265	50V 0.01uV Ceramic
C104	50V 0.01uF Ceramic	C172	16V 220uF Electrolytic	C266	50V 3pF Mica
C105	50V 0.01uF Ceramic	C173	50V 0.01uF Ceramic	C267	50V 0.01uF Ceramic
C106	50V 1pF Mica	C201	50V 0.01uF Ceramic	C268	50V 220pF Mica
C107	50V 0.01 uF Ceramic	C202	50V 0.01uF Ceramic	C269	50V 0.01uF Ceramic
C108	50V 10pF Mica	C203	50V 0.01uF Ceramic	C270	50V 0.01uF Ceramic
C109	50V 0.01uF Ceramic	C204	50V 0.01uF Ceramic	C271	50V 0.01uF Ceramic
C110	50V 0.01uF Ceramic	C205	50V 0.01uF Ceramic	C272	50V 0.01uF Ceramic
C111	50V 0.01uF Ceramic	C206	50V 0.047uF Film	C273	50V 0.01uF Ceramic
C112	50V 10pF Mica	C207	50V 0.01uF Ceramic	C274	50V 0.01uF Ceramic
C113	50V 68pF Mica	C208	50V 0.01uF Ceramic	C275	50V 68pF Mica
C114	50V 100pF Mica	C209	50V 0.01uF Ceramic	C276	50V 0.01uF Ceramic
C115	50V 0.01uF Ceramic	C210	50V 0.047uF Film	C277	50V 0.01uF Ceramic
C116	50V 0.01uF Ceramic	C211	50V 0.01uF Ceramic	C278	50V 0.01uF Ceramic
C117	50V 0.01uF Ceramic	C212	50V 3pF Mica	C279	50V 47pF Mica
C118	50V 0.01uF Ceramic	C213	50V 0.001uF Film	C280	50V 100pF Mica
C119	50V 0.001uF Film	C214	50V 0.47uF Electrolytic	C281	50V 0.01uF Ceramic
C120	50V 0.001uF Film	C215	50V 0.001uF Film	C282	50V 0.01uF Ceramic
C121	50V 0.01uF Film	C216	50V 0.001uF Film	C283	50V 0.01uF Ceramic
C122	50V 0.47uF Electrolytic	C217	50V 0.47uF Electrolytic	C284	50V 0.01uF Ceramic
C123	50V 0.01uF Ceramic	C218	50V 220pF Mica	C285	50V 100pF Mica
C124	50V 0.47 uF Electrolytic	C219	50V 220pF Mica	C286	50V 78pF Mica
C125	50V 0.01uF Ceramic	C220	50V 0.001uF Film	C287	50V 1pF Mica
C126	50V 33pF Mica	C221	50V 0.001uF Film	C288	16V 10uF Electrolytic
C127	50V 10pF Mica	C222	50V 0.47uF Electrolytic	C289	50V 0.01uF Ceramic
C128	50V 0.01uF Ceramic	C223	50V 0.47uF Electrolytic	C290	16V 10uF Electrolytic
C129	25V 1uF Electrolytic	C224	50V 0.01uF Ceramic	C291	50V 0.01uF Ceramic
C130	50V 0.01uF Ceramic	C225	50V 0.0047uF Film	C292	25V 1uF Electrolytic
C131	16V 10uF Electrolytic	C226	50V 0.01uF Ceramic	C293	6.3V 33uF Electrolytic
C132	50V 0.47uF Electrolytic	C227	50V 0.01uF Ceramic	C294	16V 10uF Electrolytic
C133	16V 100uF Electrolytic	C228	6.3V 47uF Electrolytic	C295	16V 100uF Electrolytic
C134	16V 4.7uF Electrolytic	C229	50V 0.01uF Ceramic	C296	50V 0.01uF Ceramic
C135	50V 0.047uF Film	C230	50V 0.1uF Film	C297	50V 0.01uF Ceramic
C137	50V 0.47uF Electrolytic	C231	25V 1uF Electrolytic	C298	50V 0.01uF Ceramic
C138	50V 22pF Mica	C232	6.3V 33uF Electrolytic	C299	50V 0.01uF Ceramic
C139	50V 0.01uF Ceramic	C233	16V 22uF Electrolytic	C301	16V 100uF Electrolytic
C140	50V 22pF Mica	C234	16V 4.7uF Electrolytic	C302	50V 0.01uF Ceramic
C141	50V 0.01uF Ceramic	C235	16V 10uF Electrolytic	C303	50V 0.01uF Ceramic
C142	50V 0.01uF Ceramic	C236	50V 3pF Mica	C304	50V 0.01uF Ceramic
C143	50V 68pF Mica	C237	50V 0.01uF Ceramic	C305	50V 0.01uF Ceramic
C144	50V 220pF Mica	C238	50V 220pF Mica	C306	16V 22uF Ceramic
C145	50V 0.001uF Ceramic	C239	50V 33pF Mica	C307	50V 0.01uF Ceramic
C146	50V 0.01uF Ceramic	C240	50V 33pF Mica	C308	50V 0.01uF Ceramic
C147	50V 0.01uF Ceramic	C241	50V 10pF Mica	C309	16V 10uF Electrolytic
C148	50V 0.01uF Ceramic	C242	50V 0.01uF Ceramic	C310	50V 0.01uF Ceramic
C149	16V 10uF Electrolytic	C243	50V 0.01uF Ceramic	C311	50V 78pF Mica
C150	50V 0.01uF Ceramic	C244	50V 0.001uF Ceramic	C312	50V 82pF Mica
C151	16V 22uF Electrolytic	C245	50V 0.01uF Ceramic	C313	50V 2pF Mica
C152	50V 22pF Mica	C246	50V 0.01uF Ceramic	VC101	AT1-6 variable
C153	50V 22pF Mica	C247	50V 10pF Mica	VC102	ECV-1ZW20pF variable
C154	50V 33pF Mica	C248	50V 150pF Mica	VC103	ECV-1ZW 20pF variable
C155	50V 0.01uF Ceramic	C249	50V 47pF Mica	VC104	ECV-1ZW 20pF variable
C156	16V 22uF Electrolytic	C250	50V 0.01uF Ceramic	VC105	ECV-1ZW 20pF variable
C157	50V 0.1uF Film	C251	50V 5pF Mica	VC106	ECV-1ZW 20pF variable
C158	6.3V 47uF Electrolytic	C252	50V 0.01uF Ceramic	VC107	ECV-1ZW 20pF variable
C159	16V 47uF Electrolytic	C253	50V 33pF Mica	VC108	ECV-1ZW 20pF variable
C160	50V 0.47uF Electrolytic	C254	50V 2pF Mica	VC109	ECV-1ZW 20pF variable
C161	50V 0.47uF Electrolytic	C255	50V 33pF Mica	VC110	ECV-1ZW 20pF variable
C162	6.3V 100uF Electrolytic	C256	50V 5pF Mica	VC111	ECV-1ZW 20pF variable
C163	16V 330uF Electrolytic	C257	50V 0.01uF Ceramic	VC112	ECV-1ZW 30pF variable
C164	50V 0.1uF Ceramic	C258	50V 33pF Mica	VC113	ECV-1ZW 30pF variable
C165	50V 0.01uF Ceramic	C259	50V 2pF Mica	VC114	ECV-1ZW 30pF variable
C166	50V 0.01uF Ceramic	C260	50V 0.01uF Ceramic	VC115	ECV-1ZW 30pF variable
C167	16V 220uF Electrolytic	C261	50V 3pF Mica	VC116	ECV-1ZW 30pF variable
C168	50V 0.01uF Ceramic	C262	50V 0.001uF Ceramic	VC117	ECZ-1ZW 30pF variable
				VC201	B-4 280pF variable

SEMICONDUCTORS:

<u>Part</u>	<u>Description</u>	<u>Part</u>	<u>Description</u>	<u>Part</u>	<u>Description</u>	<u>Part</u>	<u>Description</u>
Q101	2SK19Y	Q208	2SC1675-L	D111	0A90/1N60	D203	1S1588
Q102	2SC381-0	Q209	2SC1675-L	D112	0A90/1N60	D204	1S1588
Q103	2SK49	Q210	2SC1675-L	D113	1S1588	D205	0A90
Q104	2SC945-R	Q211	2SC1675-L	D114	1S1588	D206	0A90
Q105	2SC945-R	Q212	2SC381-0	D115	1S1588	D207	0A90
Q106	2SC1675-L	Q213	2SK19-Y	D116	1S1588	D208	0A90
Q107	2SC945-R	Q214	2SC1675-L	D117	1S1588	D209	1S1588
Q108	2SC945-R	Q215	2SC1675-L	D118	1S1588	D210	1S1588
Q109	2SC1675-L	Q216	2SC1330	D119	1S1588	D211	1S1588
Q110	2SC945-R	Q217	2SC1306	D120	1S1588	D212	1S1588
Q111	2SC945-R	Q218	2SC1307	D121	1S1588	D213	0A90
Q112	2SC945-R	Q219	2SC945-R	D122	1S1588	D214	0A90
Q113	2SC945-R	D101	1S1588	D123	1S1588	D215	0A90
Q114	2SC1096 4ZL	D102	1S1588	D124	1S2687	D216	0A90
Q115	2SC1096 4ZL	D103	1S1588	D125	1S1588	D217	MZ209
Q201	2SC1675-L	D104	0A90/1N60	D126	V06B	D218	MZ209
Q202	2SC1675-L	D105	0A90/1N60	D127	V06B	D219	V06B
Q203	2SC1675-L	D106	20A90	D128	BZ090	D301	TLR-103
Q204	2SC1675-L	D107	20A90	D129	005B	D302	V06B
Q205	2SC1675-L	D108	20A90	D130	1S1588	D305	TRG-103
Q206	2SC954-R	D109	20A90	D201	1S1588	D306	TLR-106
Q207	2SC1675-L	D110	1S1588	D202	1S1588		

CRYSTALS:

<u>Part</u>	<u>Description</u>	<u>Part</u>	<u>Description</u>
Y1	HG-25/U 7.8015 MHz	Y10	HC-25/U 7.4985 MHz
Y2	HC-25/U 7.7985 MHz	Y11	HC-25/U 11.705 MHz
Y3	HC-25/U 7.4615 MHz	Y12	HC-25/U 11.755 MHz
Y4	HC-25/U 7.4715 MHz	Y13	HC-25/U 11.805 MHz
Y5	HC-25/U 7.4815 MHz	Y14	HC-25/U 11.855 MHz
Y6	HC-25/U 7.5015 MHz	Y15	HC-25/U 11.905 MHz
Y7	HC-25/U 7.4585 MHz	Y16	HC-25/U 11.955 MHz
Y8	HC-25/U 7.4685 MHz	Y17	HC-25/U 7.345 MHz
Y9	HC-25/U 7.4785 MHz		

COILS & TRANSFORMERS:

<u>Part</u>	<u>Description</u>	<u>Part</u>	<u>Description</u>	<u>Part</u>	<u>Description</u>
L101	27 MHz RF Coil	L204	455 kHz IF Coil	L219	10 uH RFC
L102	27 MHz RF Coil	L205	7.8 MHz IF Coil	L220	RF
L103	27 MHz RF Coil	L206	455 kHz IF Coil	L221	27 MHz RF Coil
L104	7.8 MHz IF Coil	L207	7.8 MHz IF Coil	L222	10 uH RFC
L105	7.8 MHz IF Coil	L208	455 kHz IF Coil	L223	RF
L106	100 uH RFC	L209	455 kHz IF Coil	L224	RF
L107	7.6 MHz BM Coil	L210	7 MHz OSC Coil	L225	27 MHz RF Coil
L108	470 uH RFC	L211	19 MHz RF Coil	L226	27 MHz RF Coil
L109	7.8 MHz RF Coil	L212	19 MHz RF Coil	T1	Choke coil
L110	470 uH RFC	L213	19 MHz RF Coil	T2	Output
L111	470 uH RFC	L214	19 MHz RF Coil	T3	Driver
L112	11 MHz RF Coil	L215	27 MHz RF Coil	F1	SF0724A 7.8 MHz Crystal Filter
L201	7.8 MHz IF Coil	L216	27 MHz RF Coil	F2	LF-6B Ceramic Filter
L202	455 kHz IF Coil	L217	27 MHz RF Coil		
L203	7.8 MHz IF Coil	L218	27 MHz RF Coil		

MISCELLANEOUS:

<u>Part</u>	<u>Description</u>	<u>Part</u>	<u>Description</u>
S1	Channel switch	J4	Microphone connector
S2	Mode switch (AM-SSB)	J5	Meter jack
S3	PA-CB switch		SJ-289 1-5
S5	Noise blanker switch		Microphone
S6	Mode switch (USB-LSB)		Pilot lamp
M	S-RF indicator		Fuse holder
	Relay		Fuse
	Relay socket	MH-4P	Microphone connector
	Crystal socket		Knob
	Speaker	EAS-9D75SA	Knob
J1	PA, SP jack	SJ-295	Cage
J2	EXT SP jack	SJ-295	Wing bolt
J3	Antenna connector		Rubber feet
			L1
			VR301,VR302,VR303,VR305

—— ABBREVIATED CITIZENS RADIO 10-CODE ——

10-1	Receiving poorly	10-37	Wrecker needed at _____
10-2	Receiving well	10-38	Ambulance needed at _____
10-3	Stop transmitting	10-39	Your message delivered
10-4	OK, message received	10-41	Please tune to channel _____
10-5	Relay message	10-42	Traffic accident at _____
10-6	Busy, stand by	10-43	Traffic tieup at _____
10-7	Out of service, leaving air	10-44	I have a message for you (or _____)
10-8	In service, subject to call	10-45	All units within range please report
10-9	Repeat message	10-50	Break channel
10-10	Transmission completed, standing by	10-60	What is next message number
10-11	Talking too rapidly	10-62	Unable to copy, use phone
10-12	Visitors present	10-63	Net directed to _____
10-13	Advise weather/road conditions	10-64	Net clear
10-16	Make pickup at _____	10-65	Awaiting your next message/assignment
10-17	Urgent business	10-67	All units comply
10-18	Anything for us?	10-70	Fire at _____
10-19	Nothing for you, return to base	10-71	Proceed with transmission in sequence
10-20	My location is _____	10-73	Speed trap at _____
10-21	Call by telephone	10-75	You are causing interference
10-22	Report in person to _____	10-77	Negative contact
10-23	Stand by	10-81	Reserve hotel room for _____
10-24	Completed last assignment	10-82	Reserve room for _____
10-25	Can you contact _____	10-84	My telephone number is _____
10-26	Disregard last information	10-85	My address is _____
10-27	I am moving to channel _____	10-89	Radio repairman needed at _____
10-28	Identify your station	10-90	I have TVI
10-29	Time is up for contact	10-91	Talk closer to mike
10-30	Does not conform to FCC rules	10-92	Your transmitter is out of adjustment
10-32	I will give you a radio check	10-93	Check my frequency on this channel
10-33	Emergency traffic at this station	10-94	Please give me a long count
10-34	Trouble at this station, help needed	10-95	Transmit dead carrier for 5 sec.
10-35	Confidential information	10-99	Mission completed, all units secure
10-36	Correct time is _____	10-200	Police needed at _____

—— CB CHANNEL TO MEGAHERTZ CHART ——

<u>CHANNEL</u>	<u>FREQUENCY</u> (MHz)	<u>CHANNEL</u>	<u>FREQUENCY</u> (MHz)
1.	26.965	13.	27.115
2.	26.975	14.	27.125
3.	26.985	15.	27.135
4.	27.005	16.	27.155
5.	27.015	17.	27.165
6.	27.025	18.	27.175
7.	27.035	19.	27.185
8.	27.055	20.	27.205
9.	27.065	21.	27.215
10.	27.075	22.	27.225
11.	27.085	23.	27.255
12.	27.105		

KRIS INC.

N144 W5660 Pioneer Rd., Cedarburg, WI 53012